



a marca do alumínio
the aluminium brand

n14 600 REAL

REABILITAÇÃO EM ALUMÍNIO
ALUMINIUM REHABILITATION

SISTEMA DE BATENTE COM
RUTURA DE PONTE TÉRMICA

CASEMENT SYSTEM WITH THERMAL BREAK



n14 600 REAL

SISTEMA DE BATENTE COM RUTURA DE PONTE TÉRMICA

CASEMENT SYSTEM WITH THERMAL BREAK

O SISTEMA N14 600 TEM PELO SEU DESENHO AS CARACTERÍSTICAS IDEAIS PARA UTILIZAÇÃO EM PROJETOS DE REABILITAÇÃO

THE DESIGN OF THE N14 600 SYSTEM GIVES IT THE IDEAL FEATURES FOR THE USE IN REHABILITATION

Resulta num sistema com boas performances térmica e acústica, possibilitando também a sua aplicação em projetos de arquitetura contemporâneos. Com aro fixo de 67,4mm e utilizando acessórios de câmara europeia, este sistema permite a aplicação de uma vasta gama de bites para múltiplas soluções de vidro duplo. Permite ainda diferentes possibilidades de acabamentos, incluindo bicolor e efeito madeira. O seu desenho em alçado caracteriza-se por um interior de folha coplanar com o aro fixo e no exterior a folha e o aro fixo trabalham em diferentes planos. Sistema desenvolvido tendo em conta a temática ecológica, desde o processo de produção à utilização de materiais.

This system has a good thermic and acoustic performance, enabling its application in contemporary architectural projects. With fixed frame of 67,4mm and working with European chamber accessories, this system allows the application of a wide range of bits for multiple glazing solutions of double glass. The system also allows different possibilities of surface finishing, including bicolour and wood effects. Its elevation drawing is characterized by an inner coplanar sheet with the outer fixed frame. In the exterior the pane and the fixed frame work at different plans. This system was developed taking into account ecological issues, from the production process to the use of materials.

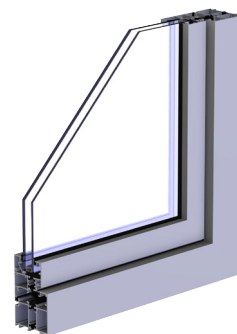
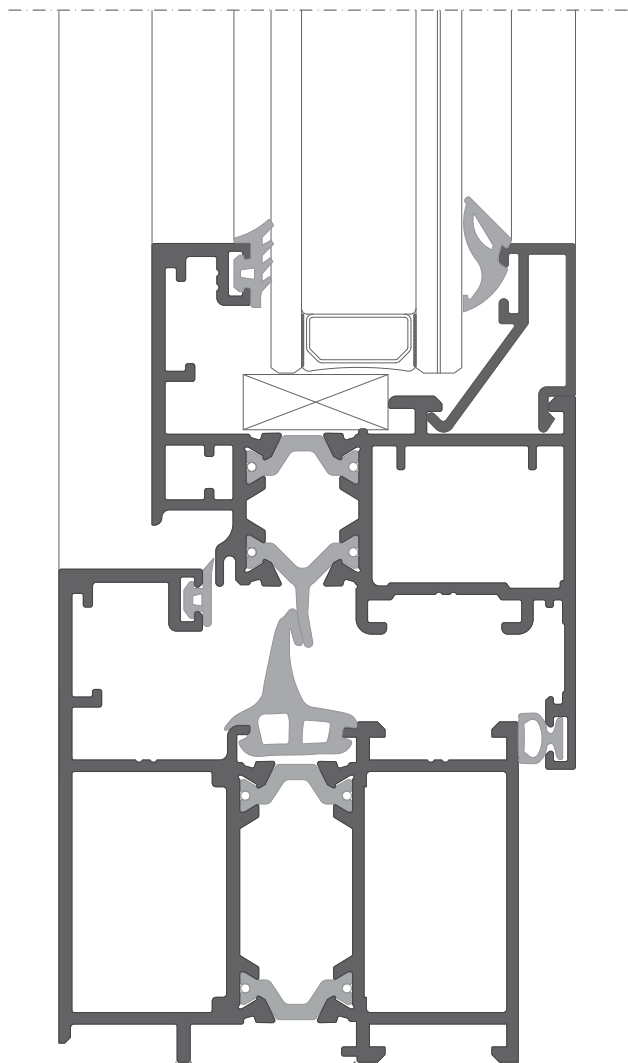

PORMENORES DE MONTAGEM SYSTEM SECTIONS

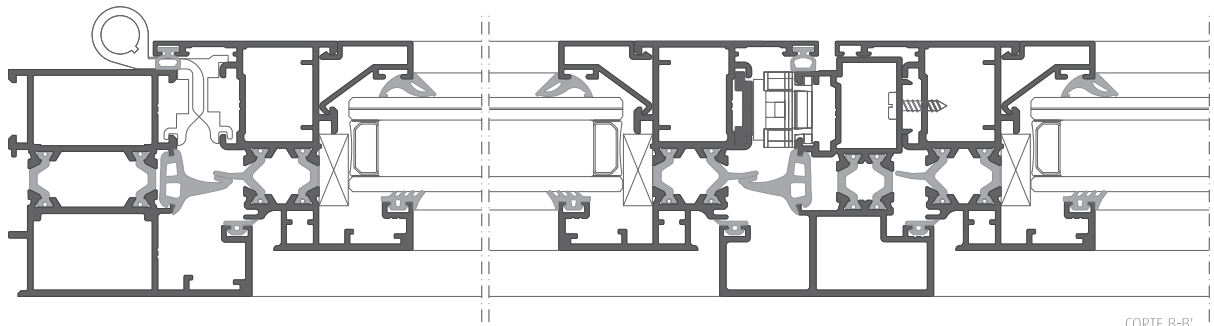
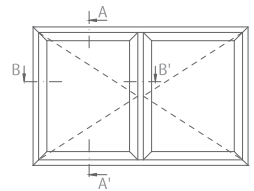
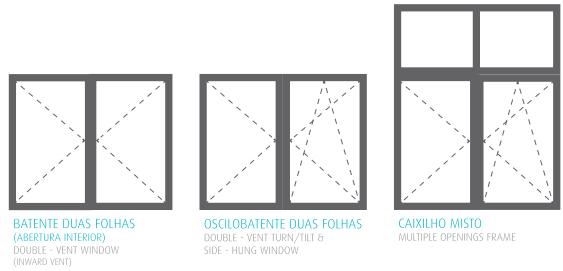
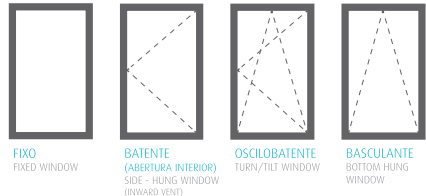
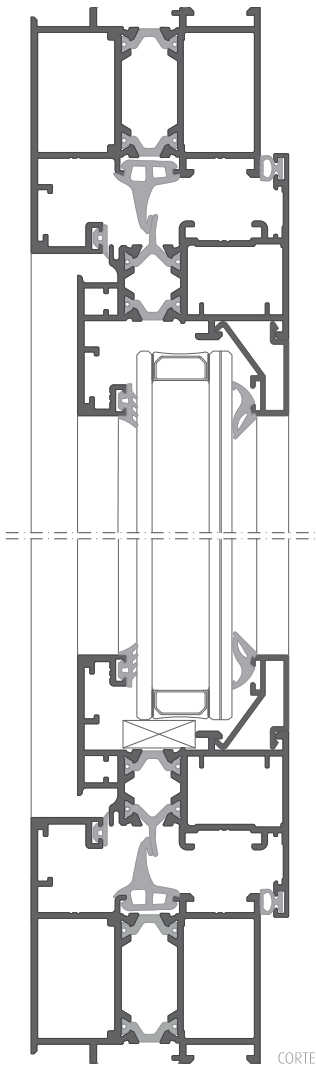

AROS FIXOS | OUTER FRAMES

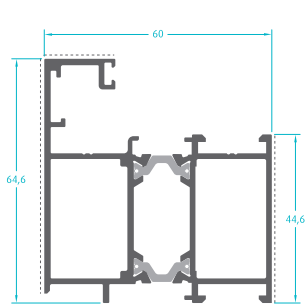

n14 603

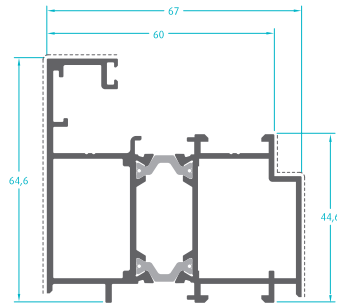

n14 604

TRAVESSAS MONTANTES | TRANSOMS/MULLIONS

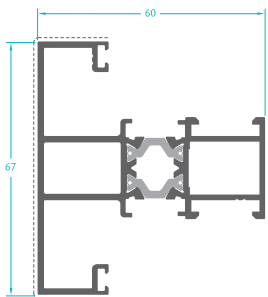

n14 611

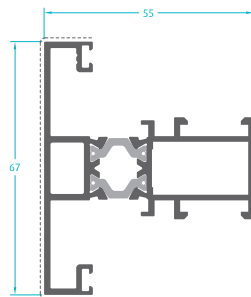

n14 613

FOLHA | VENT

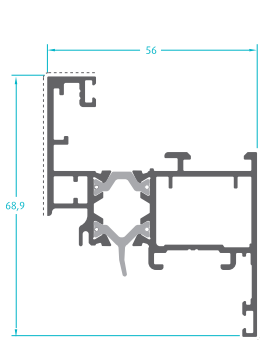

n14 622

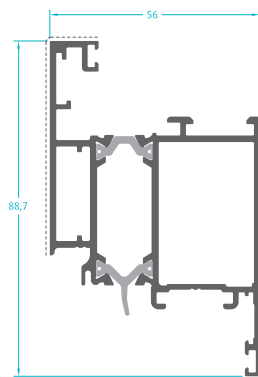

n14 632

INVERSOR | INVERTER

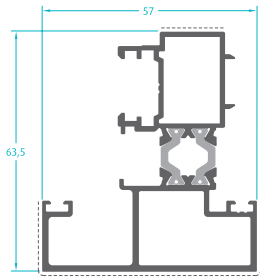

n14 671

DIVERSOS | GENERAL

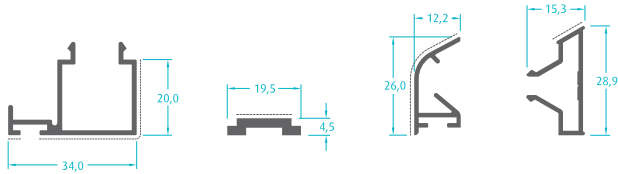

n12 074

n12 094

n12 096

n12 097

BITES | GLAZING BEADS

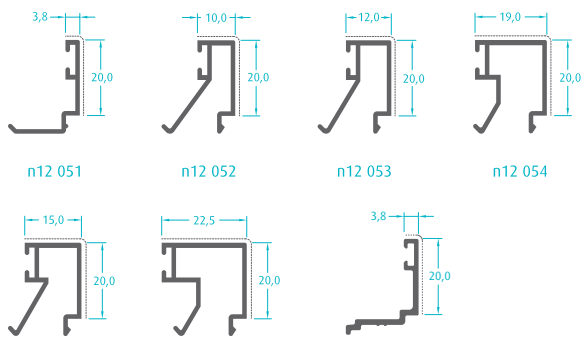

n12 051

n12 052

n12 053

n12 054

n12 058

n12 059

n12 156

grupo  **navarra**

www.navarraaluminio.com

 **navarra**
extrusão de alumínio



 **navarra**
alumínio para arquitetura

 **n.2.a.**
grupo navarra

 **navarra**
moçambique

A Navarra - Extrusão de Alumínio, S.A. reserva-se no direito de proceder sem aviso prévio a alterações em todo ou parte do conteúdo apresentado. Para atualizações consulte www.navarraaluminio.com

Navarra - Extrusão de Alumínio, S.A. reserves the right to alter in part or all of the content presented without prior notice. For updates visit www.navarraaluminium.com



Evite a reprodução deste documento. O planeta agradece.
Please, avoid reproducing this document. The planet will be grateful.